

CARGO SHIFTER





CARGO SHIFTER
TOUGH AND UNCOMPROMISED
MULTI-PURPOSE MOVER

Brian James Trailers have created **CarGO Shifter's** every detail to deliver the ultimate performance and operating benefit. Strong but light is one of the main attractions of **Brian James Trailers'** design. In use it becomes immediately apparent just how capable the **Shifter** is.

Durability is without question, function with no equals. Spoilt for choice in sizes and configurations, the **CarGO Shifter** has every chance of becoming an important part of your daily operation.



CARGO SHIFTER

CARGO SHIFTER MOVING EXPECTATIONS.

As with all **Brian James Trailers**, the **CarGO Shifter** enjoys a reputation for being easy to load and tow.

To achieve this the team focused on the chassis where strength and tow-ability are defined. By selecting high specification steels for fabrication, the chassis has been made strong and light.

Clever chassis design also supports the tough phenolic deck along its full length, which allows heavy items such as rollers to be transported. The extra support extends the life span of the trailer.



○ Removable **high mesh sides** are a popular option for carrying bulky loads. The individual panels unclip with minimal effort and are designed to maximise strength with minimum weight.

● The robust **running gear** features class leading running gear equipment manufactured by AL-KO, a fully independent suspension. Sealed bearings require minimum maintenance.

The **Shifter** is a capable general purpose trailer.

● Machinery security has been catered for with many unique **tie-down points**, highlighting inherent versatility. Innovative **rope hooks** and **slots** are cut into the **chassis**. It is multiple-hook compatible and totally silent when travelling.

● **Non slip side-steps** are another **CarGO Shifter** feature allowing easy side access and forms pedestrian safety guards.

● The **anti slip deck** is standard. The tough and durable phenolic bonded industrial plywood has a mesh grip pattern surface. The super strong deck design with central steel section ensures that heavy loads will not damage the integrity of the bed.





● Standard. ○ Optional at extra cost.

CARGO SHIFTER.

CARGO SHIFTER

CARGO SHIFTER

WHAT YOU NEED.



- The **tail ramp** is operated with a powerful gas spring. Minimal effort is required to lift or lower the ramp.

- **Rear load support stand bar** fixed to the ramp. Standard on single axle.

- **Number plate holder** provides quick release facility, without fasteners.

- **Mudguards** are fully integrated into the chassis for durability. High grip surface offers operator safety.

- **Side steps** on each available corner assist operators to work around the trailer safely and conveniently.



- **Heavy duty mesh tail ramp** with aluminium checker plate lower section provides the best combination of easy operation, low loading angle, limited wind resistance and exceptional durability.

- **Reinforced anti slip deck** ensures that destructive equipment such as rollers will not cause damage.

- **Rope hooks / slots.** Multiple attachment points along both sides and front for securing loads with ropes.

- **Cast steel head.**
Integrated coupling lock.
- **Jockey wheel**
heavy duty jockey wheel.



- **Rear lamps** are well protected from damage in steel housings. Fully type approved installation to EEC standard.

- **ACME thread clamps.** Silent locked – the loading tail ramp is held in place with secure clamp fasteners. A rubber buffer is part of the system and provides damping for quiet travel.



- **Removable high mesh sides** add 0.80m to the height of the sides. These are a popular option for carrying bulky loads. The individual extension panels unclip with minimal effort and are designed to maximise strength with minimum weight.

- **Low chassis** means low loading angles, plus an inherent stability with a low centre of gravity for heavy loads.

- Ramp features **handles** on each side.



- **Front marker lamps.** Fully type approved lighting installation to EEC standard.

CARGO SHIFTER

CARGO SHIFTER

FULLY EQUIPPED.

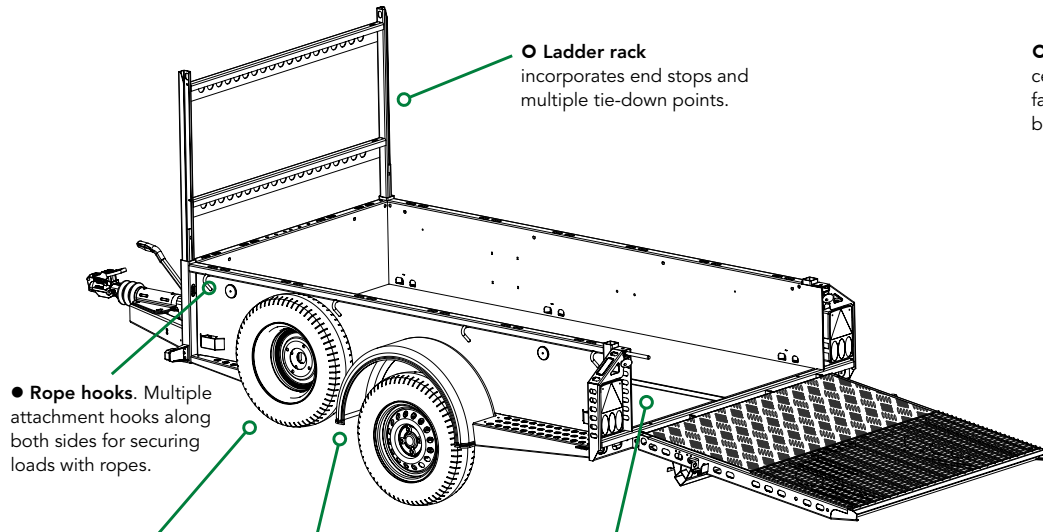

● **Rope hooks.** Multiple attachment hooks along both sides for securing loads with ropes.

● **165 6pr wheel / tyre** side mounted spare.

● **Single axle model.** High impact polyethylene mudguard.

● **Anti slip deck.** Tough and durable phenolic bonded industrial plywood has a mesh grip pattern surface. A super strong deck design with central steel section ensures that heavy loads will not damage the integrity of the bed.

○ **Ladder rack** incorporates end stops and multiple tie-down points.

○ **Manual winch** provides central pull through roller fairlead. 2 speed with brake and steel cable.

● **Heavy duty mesh ramp.** Welded mesh and aluminium checker plate. Strong, good grip plus a low loading angle.

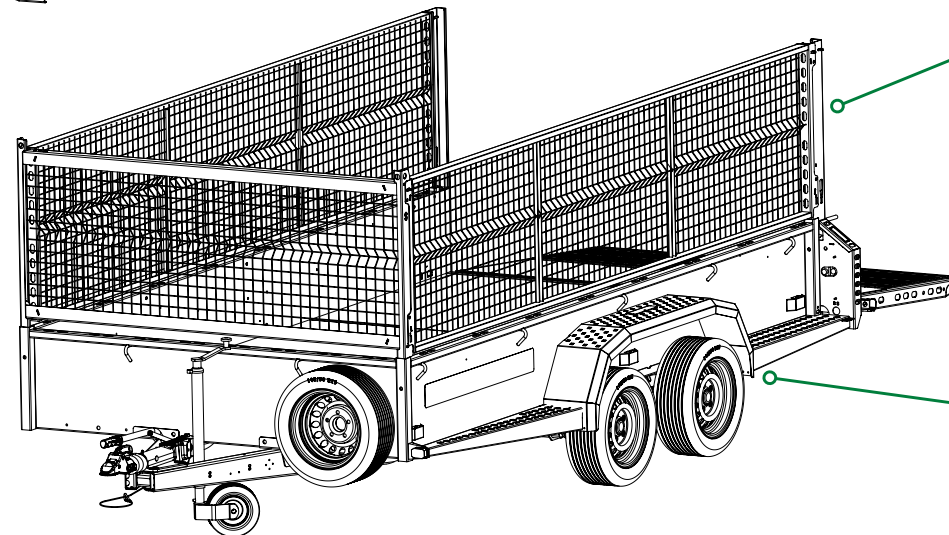
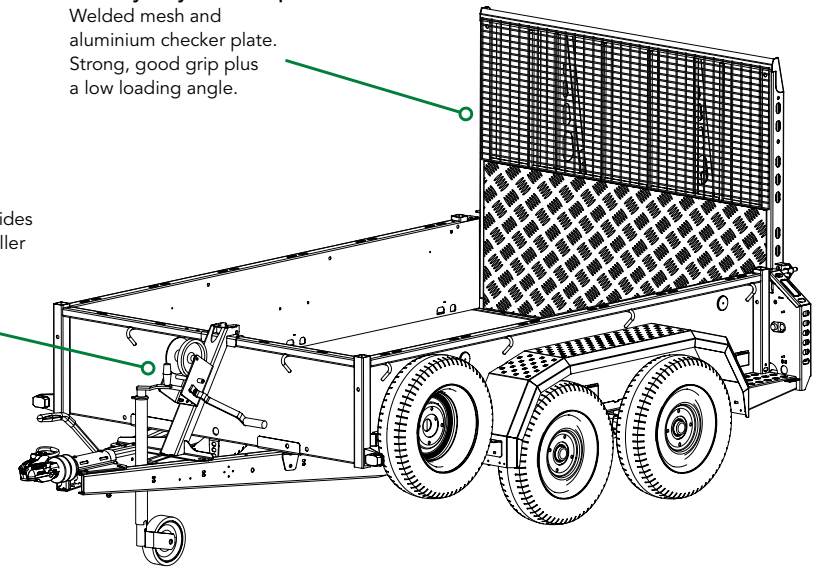

○ **Removable high mesh sides** add 0.80m to the height of the sides. These are a popular option for carrying bulky loads. The individual extension panels unclip with minimal effort and are designed to maximise strength with minimum weight.

● **Mudguards and side steps** are integrated into the chassis for durability. High grip punched surface offers operator safety. (Twin axles.)

TECHNICAL INFORMATION.

LOAD BED LENGTH m	2.50				3.10				3.70		4.00	
CAPACITY												
Gross kg	1,300	1,300	1,500	1,500	2,600	2,600	2,600	2,600	3,000	3,000	3,500	3,500
Load kg	850	850	1,050	1,050	2,030	2,030	1,970	1,950	2,350	2,350	2,800	2,700
DIMENSIONS												
Internal bed width m	1.30	1.60	1.30	1.60	1.30	1.60	1.60	1.85	1.60	1.85	1.85	1.85
Overall trailer width m	1.82	2.12	1.82	2.12	1.82	2.12	2.12	2.30	2.12	2.30	2.30	2.30
Overall trailer length m	3.92	3.92	3.92	3.77	3.95	3.94	4.37	4.44	4.37	5.06	5.06	5.33
Bed load height m	0.39	0.39	0.39	0.39	0.39	0.39	0.39	0.39	0.39	0.39	0.39	0.39
RUNNING GEAR AND SECURITY												
Axles	1	1	1	1	2	2	2	2	2	2	2	2
Wheel / Tyre size	13" (165 6pr)	13" (165 6pr)	13" (195/50)	13" (195/50)	13" (165 6pr)	13" (165 6pr)	13" (165 6pr)	13" (165 6pr)	13" (195/50)	13" (195/50)	13" (195/50)	13" (195/50)
Sealed wheel bearings	●	●	●	●	●	●	●	●	●	●	●	●
Spare wheel	●	●	●	●	●	●	●	●	●	●	●	●
Tie-down anchor points (internal)	6 points	6 points	6 points	6 points	6 points	6 points	6 points	6 points	6 points	6 points	6 points	8 points
Tie-down straps x 4	○	○	○	○	○	○	○	○	○	○	○	○
Wheels-Safety kit – torque wrench + digital tyre pressure gauge	○	○	○	○	○	○	○	○	○	○	○	○
Cast steel coupling head with integral high security lock	●	●	●	●	●	●	●	●	●	●	●	●
Datatag – Security identification system	○	○	○	○	○	○	○	○	○	○	○	○
BED AND REAR LOADING												
Phenol ply anti slip, reinforced deck	●	●	●	●	●	●	●	●	●	●	●	●
Aluminium tread plate bed lining	○	○	○	○	○	○	○	○	○	○	○	○
Aluminium + mesh tail ramp + gas spring assistance	●	●	●	●	●	●	●	●	●	●	●	●
Rear load support stand (bar)	●	●	●	●	○	○	○	○	○	○	○	○
SIDE OPTIONS												
High mesh side extensions 0.80m (removable)	○	○	○	○	○	○	○	○	○	○	○	○
Ladder rack	○	○	○	○	○	○	○	○	○	○	○	○
WINCH												
Manual winch 2 speed + brake	○	○	○	○	○	○	○	○	○	○	○	○
PRODUCTS												
Product code	500-0000	500-0010	500-0100	500-0110	500-0200	500-0210	500-1200	500-1220	500-1400	500-2400	500-2600	500-3600

● Standard. ○ Optional at extra cost.

CARGO SHIFTER.